

Discø Lights

- To start the device, press and hold PWR button until all LEDs have lit up, then release.
- Click BTN2 to cycle forwards through patterns, and BTN1 to cycle backwards.
- Hold BTN1 and click BTN2 to change color for the current pattern. Hold BTN2 and click BTN1 to cycle backwards
- Hold BTN2 for more than 0.5s to increase color intensity. Hold BTN1 for more than 0.5s to decrease color intensity
- Press both BTN1 and BTN2 simultaneously to show battery status
- To turn the device off, press and hold PWR button until all LEDs have turned off, then release.

Assembly Manual

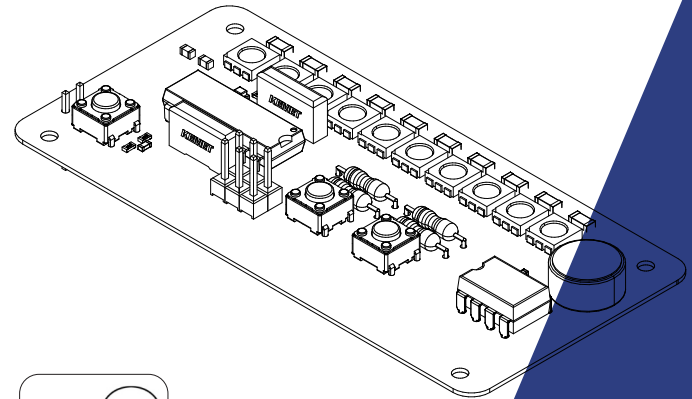

INSTRUCTIONS

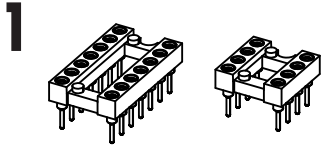

Install the IC sockets. Make sure they are facing the correct way by looking for the small indent, and align it with the markings on the PCB (circuit board).

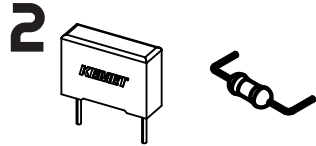

Install the capacitors (grey boxes) and the resistors. NOTE: R1, R2 are 1k, whereas R3, R4 are 10k.

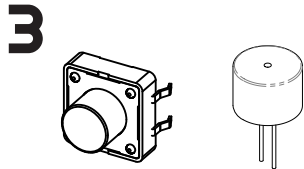

Install the buttons and the microphone. They will only fit one way which you will see.



PARTY!

